

60V N-Channel Power MOSFET

DESCRIPTION

The BLM08N06L uses advanced trench technology to provide excellent $R_{DS(ON)}$, low gate charge. It can be used in a wide variety of applications.

Application

- Power switching application
- Hard switched and High frequency circuits
- Uninterruptible power supply

KEY CHARACTERISTICS

- $V_{DS} = 60V, I_D = 80A$ (TO-220/252); $I_D = 12A$ (SOP-8)
- $R_{DS(ON)} < 8.0m\Omega @ V_{GS} = 10V$ (TO-220/ 252)
- $R_{DS(ON)} < 10.0m\Omega @ V_{GS} = 10V$ (SOP-8)
- Special process technology for high ESD capability
- High density cell design for lower R_{Dson}
- Fully characterized avalanche voltage and current
- Good stability and uniformity with high EAS
- Excellent package for good heat dissipation

100% UIS TESTED!

100% DVDS TESTED!



TO-220 Top View

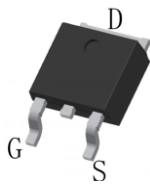

TO-252-2L Top View

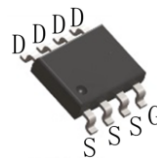

SOP-8 Top View

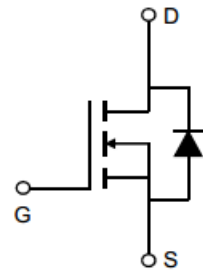

Schematic diagram

Package Marking And Ordering Information

Device Marking	Ordering Codes	Package	Product Code	Packing
M08N06L	BLM08N06L-P	TO-220	BLM08N06L	Tube
M08N06L	BLM08N06L-D	TO-252-2L	BLM08N06L	Tape Reel
M08N06L	BLM08N06L-E	SOP-8	BLM08N06L	Tape Reel

Absolute Maximum Ratings (TA=25°C unless otherwise noted)

Parameter	Symbol	Limit	Unit
Drain-Source Voltage	V_{DS}	60	V
Gate-Source Voltage	V_{GS}	± 20	V
Drain Current-Continuous	$I_D(TO-220/252)$	80	A
	$I_D(SOP-8)$	12	A
Drain Current-Pulsed (Note 1)	$I_{DM}(TO-220/252)$	320	A
	$I_{DM}(SOP-8)$	120	A
Maximum Power Dissipation ($T_c = 25^\circ C$)	$P_D(TO-220/252)$	110	W
	$P_D(SOP-8)$	3	W
Single pulse avalanche energy (Note 2)	E_{AS}	390	mJ
Operating Junction and Storage Temperature Range	$T_J, T_{STG}(TO-220/252)$	-55 To 175	$^\circ C$
Operating Junction and Storage Temperature Range	$T_J, T_{STG}(SOP-8)$	-55 To 150	$^\circ C$

Thermal Characteristic

Thermal Resistance,Junction-to-Case	$R_{\theta JC}(TO-220/252)$	1.36	$^{\circ}C/W$
Thermal Resistance,Junction-to-Ambient	$R_{\theta JA}(SOP-8)$	42	$^{\circ}C/W$

Electrical Characteristics (TA=25°C unless otherwise noted)

Parameter	Symbol	Condition	Min	Typ	Max	Unit
Off Characteristics						
Drain-Source Breakdown Voltage	BV_{DSS}	$V_{GS}=0V, I_D=250\mu A$	60	-	-	V
Zero Gate Voltage Drain Current	I_{DSS}	$V_{DS}=60V, V_{GS}=0V$	-	-	1	μA
Gate-Body Leakage Current	I_{GSS}	$V_{GS}=\pm 20V, V_{DS}=0V$	-	-	± 100	nA
On Characteristics						
Gate Threshold Voltage	$V_{GS(th)}$	$V_{DS}=V_{GS}, I_D=250\mu A$	1	1.9	2.5	V
Drain-Source On-State Resistance ^(Note 3)	$R_{DS(on)}$	$V_{GS}=10V, I_D=20A(TO-220/252)$	-	7	8	m Ω
		$V_{GS}=10V, I_D=12A(SOP-8)$	-	8.6	10	m Ω
Forward Transconductance	g_{FS}	$V_{DS}=10V, I_D=20A$	-	20	-	S
Dynamic Characteristics						
Input Capacitance	C_{iss}	$V_{DS}=30V, V_{GS}=0V,$ $f=1.0MHz$	-	4000	-	pF
Output Capacitance	C_{oss}		-	290	-	pF
Reverse Transfer Capacitance	C_{rss}		-	210	-	pF
Switching Characteristics ^(Note 4)						
Turn-on Delay Time	$t_{d(on)}$	$V_{DD}=30V, I_D=30A,$ $V_{GS}=10V, R_{GEN}=3\Omega$	-	8.5	-	nS
Turn-on Rise Time	t_r		-	7	-	nS
Turn-Off Delay Time	$t_{d(off)}$		-	40	-	nS
Turn-Off Fall Time	t_f		-	15	-	nS
Total Gate Charge	Q_g	$V_{DS}=30V, I_D=20A$ $V_{GS}=10V$	-	90	-	nC
Gate-Source Charge	Q_{gs}		-	9	-	nC
Gate-Drain Charge	Q_{gd}		-	18	-	nC
Drain-Source Diode Characteristics						
Diode Forward Voltage	V_{SD}	$V_{GS}=0V, I_S=20A$	-	-	1.2	V

Notes:

1. Repetitive Rating: Pulse width limited by maximum junction temperature.
2. EAS condition : $T_j=25^{\circ}C, V_{DD}=20V, V_G=10V, L=0.5mH, R_g=25\Omega$
3. Pulse Test: Pulse Width $\leq 300\mu s$, Duty Cycle $\leq 2\%$.
4. Guaranteed by design, not subject to production.

Characteristics Curves
Figure 1 Output Characteristics

Figure 2 Transfer Characteristics

Figure 3 On-Resistance vs. I_D and V_{GS}

Figure 4 On-Resistance vs. Junction Temperature

Figure 5 On-Resistance vs. V_{GS}

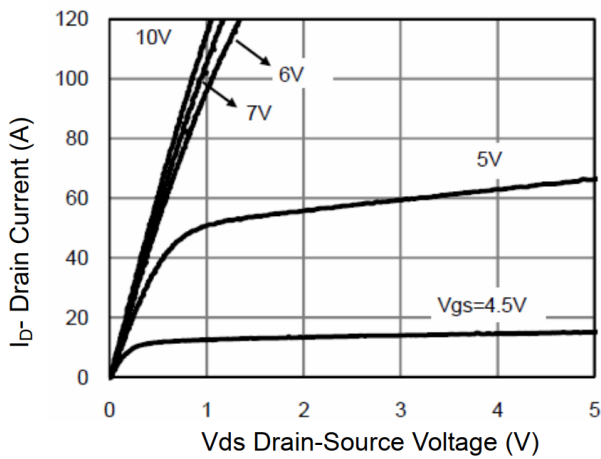
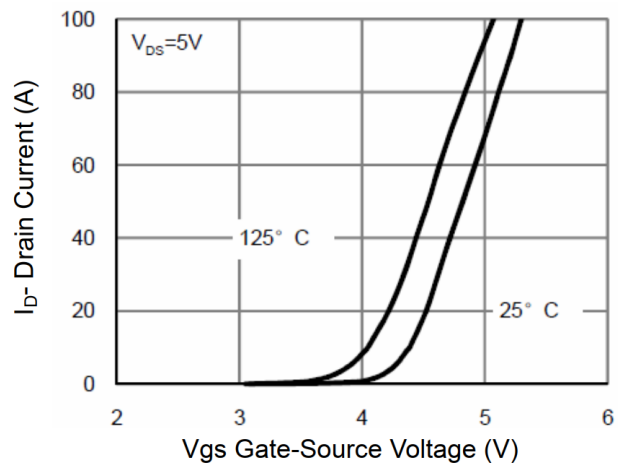
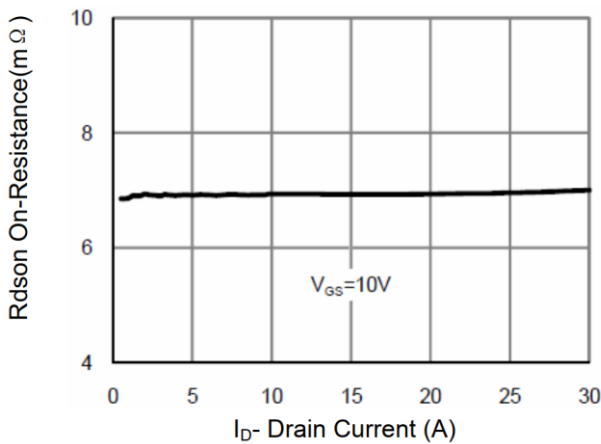
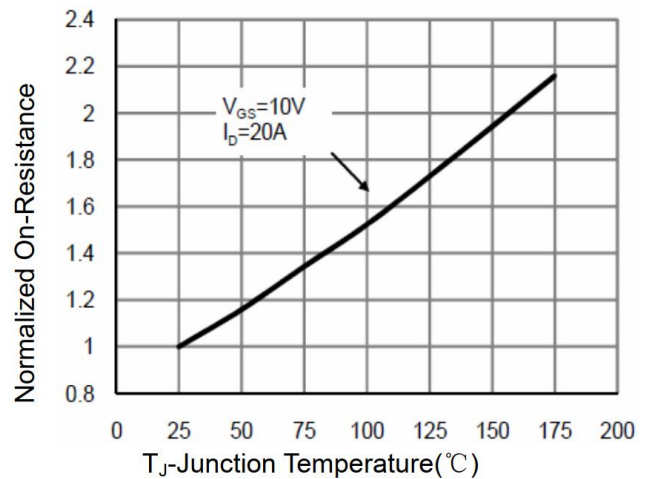
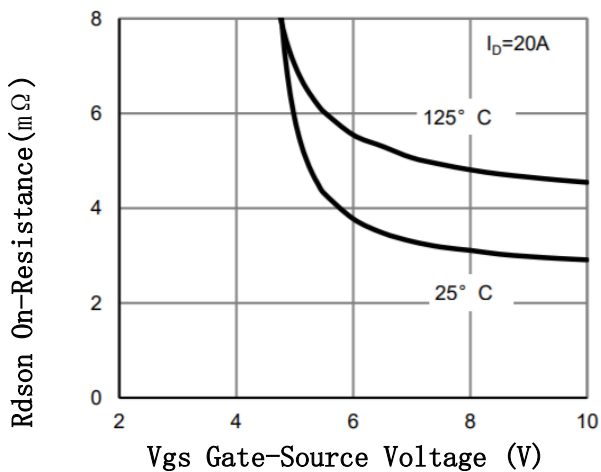
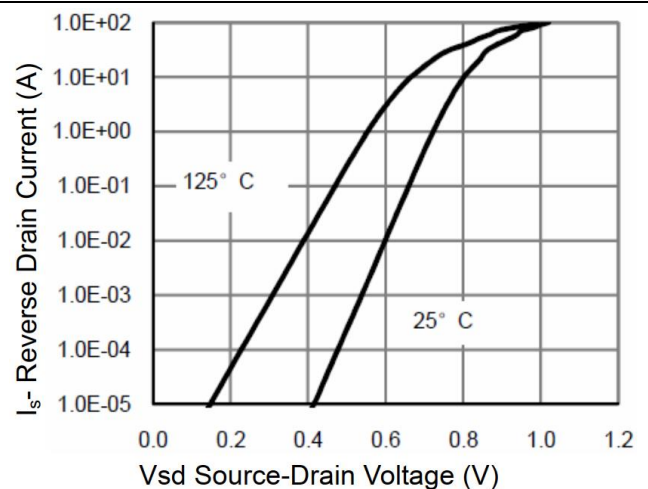
Figure 6 Body Diode Forward Voltage

Figure 7 Gate-Charge Characteristics

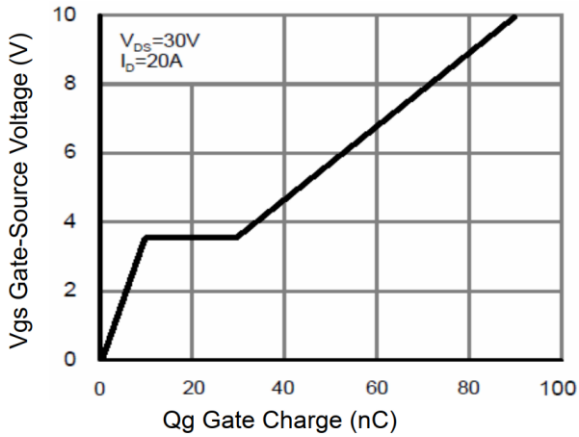

Figure 8 Capacitance Characteristics

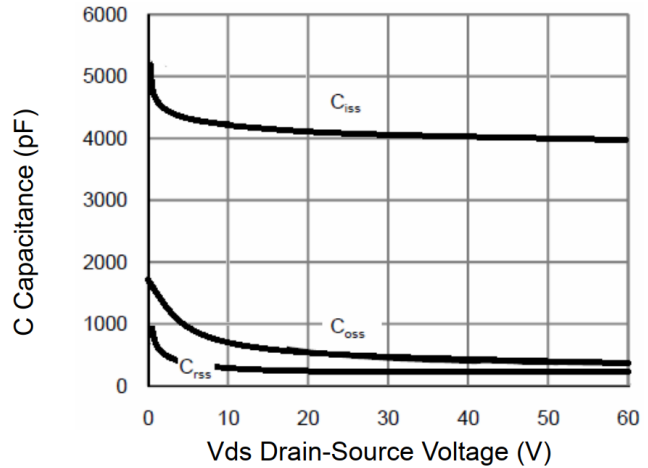

Figure 9a Maximum Forward Biased Safe Operation Area (TO-220/252)

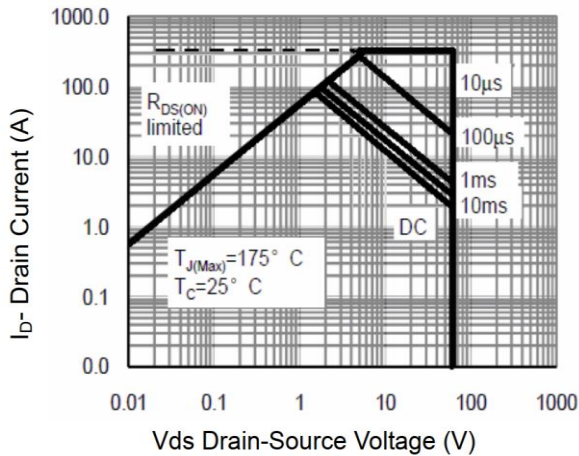

Figure 9b Maximum Forward Biased Safe Operation Area (SOP-8)

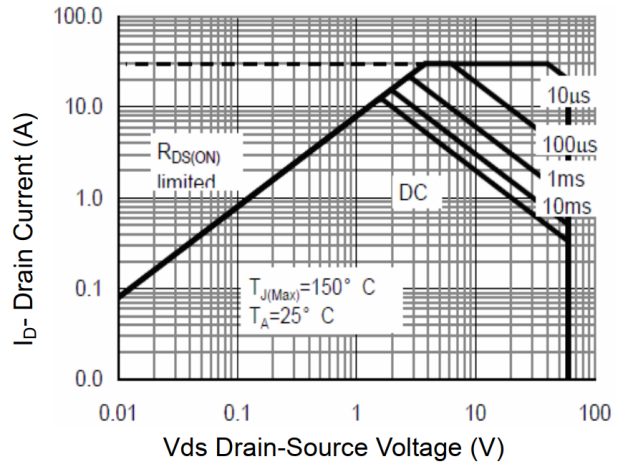

Figure 10a Single Pulse Power Rating Junction-to-Ambient (TO-220/252)

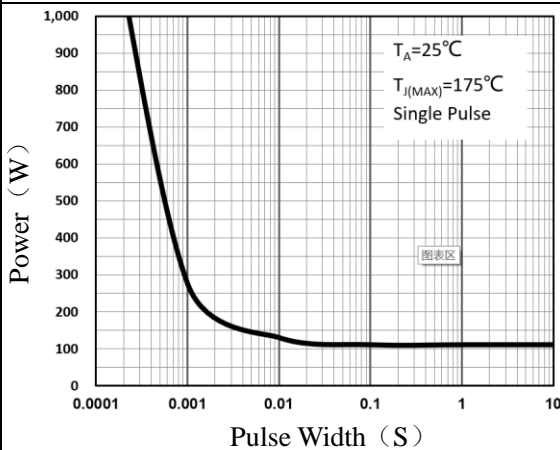

Figure 10b Single Pulse Power Rating Junction-to-Ambient (SOP-8)

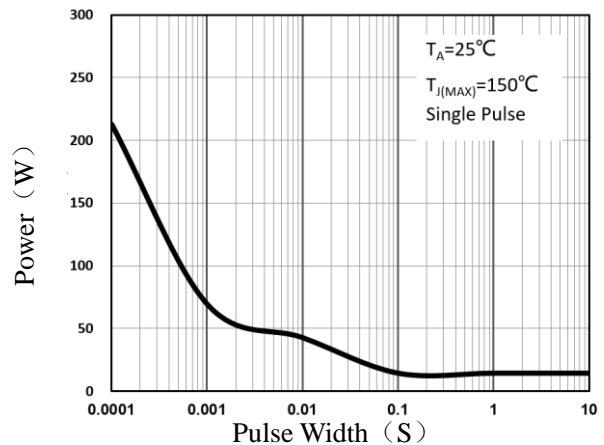

Figure 11a Normalized Maximum Transient Thermal Impedance (TO-220/252)

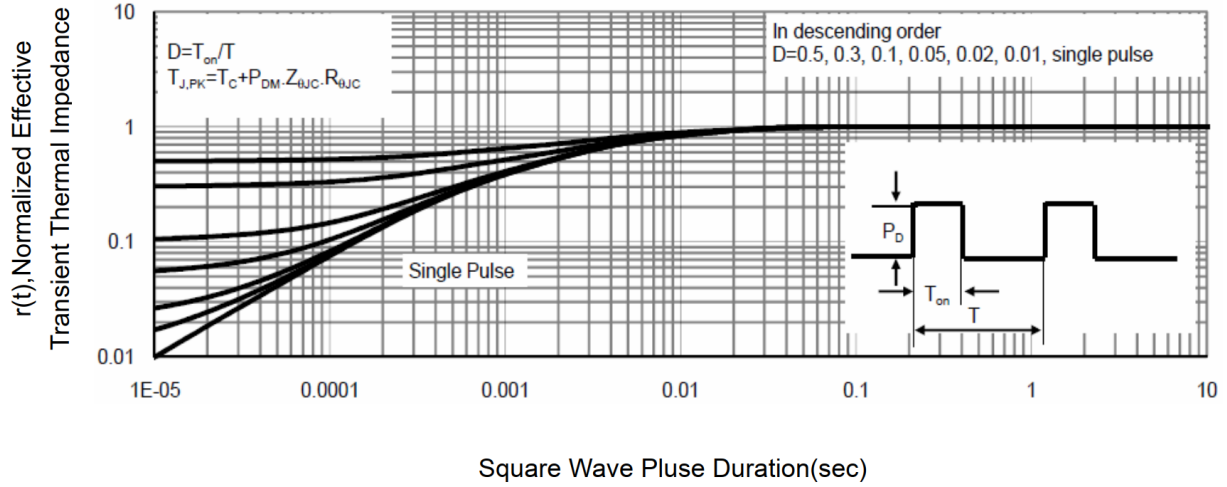
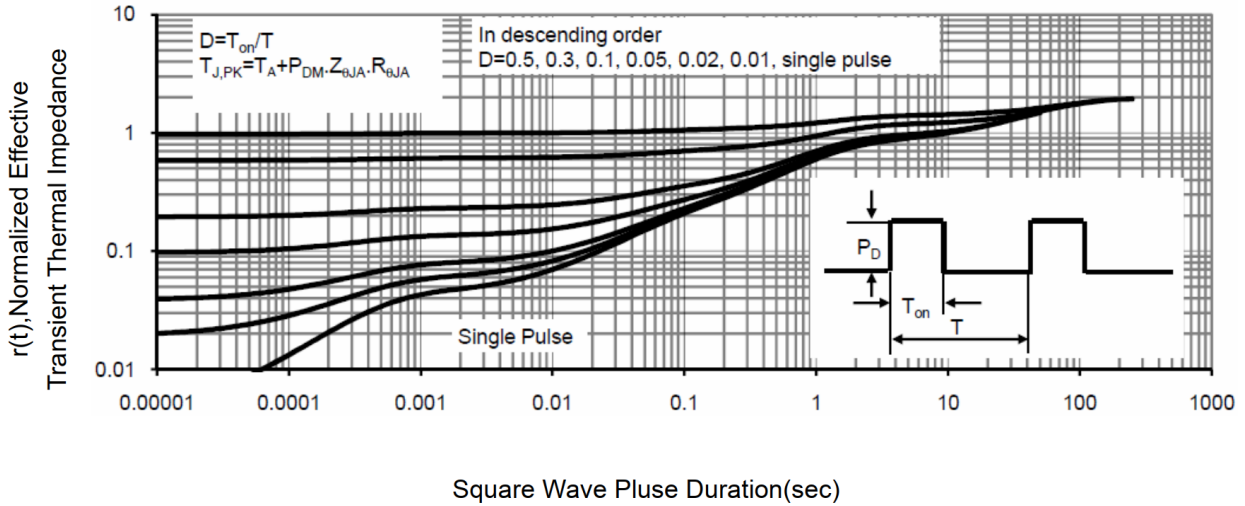
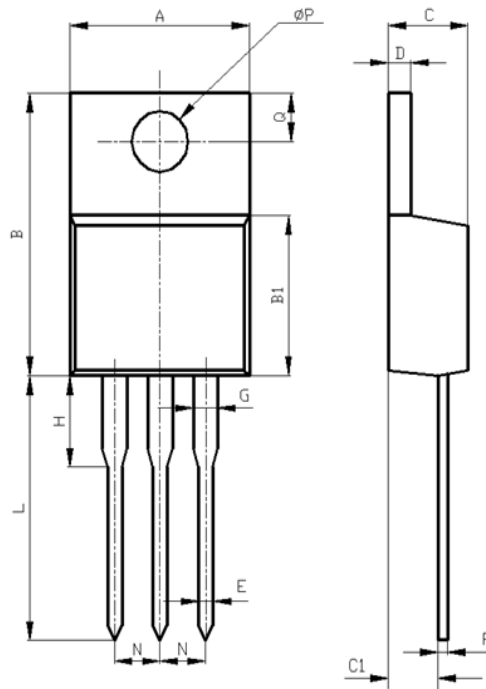

Figure 11b Normalized Maximum Transient Thermal Impedance (SOP-8)



Package Description



Items	Values(mm)	
	MIN	MAX
A	9.60	10.6
B	15.0	16.0
B1	8.90	9.50
C	4.30	4.80
C1	2.30	3.10
D	1.20	1.40
E	0.70	0.90
F	0.30	0.60
G	1.17	1.37
H	2.70	3.80
L	12.6	14.8
N	2.34	2.74
Q	2.40	3.00
ϕP	3.50	3.90

TO-220 Package

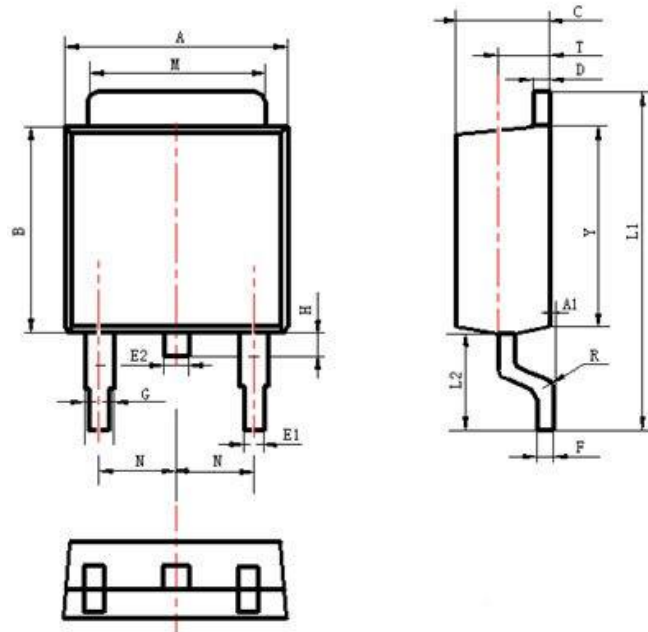

Items	Values(mm)	
	MIN	MAX
A	6.30	6.90
A1	0	0.13
B	5.70	6.30
C	2.10	2.50
D	0.30	0.60
E1	0.60	0.90
E2	0.70	1.00
F	0.30	0.60
G	0.70	1.20
L1	9.60	10.50
L2	2.70	3.10
H	0.60	1.00
M	5.10	5.50
N	2.09	2.49
R	0.3	
T	1.40	1.60
Y	5.10	6.30

TO-252 Package

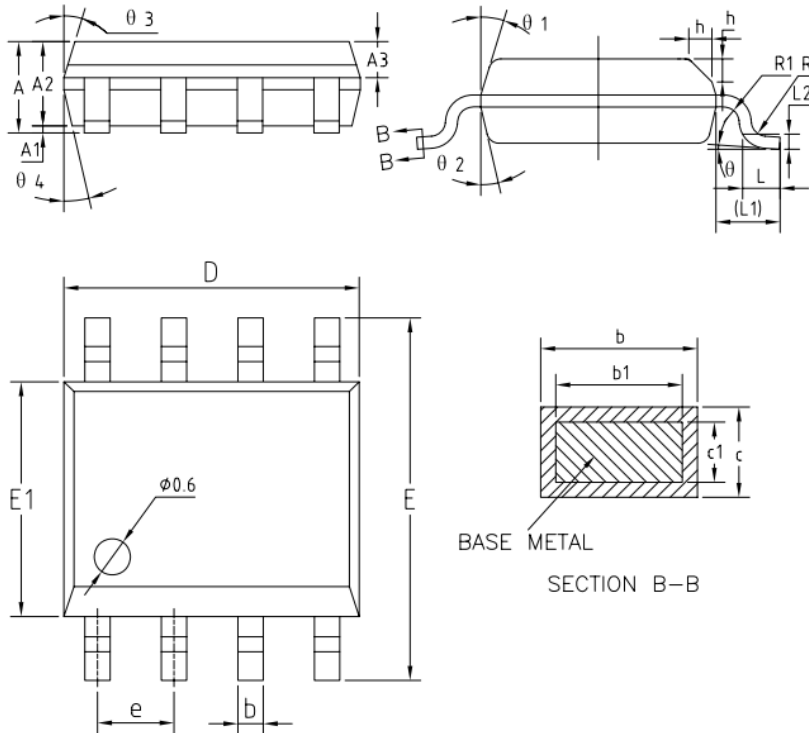

COMMON DIMENSIONS
 (UNITS OF MEASURE=MILLIMETER)

SYMBOL	MIN	NOM	MAX
A	1.35	1.55	1.75
A1	0.10	0.15	0.25
A2	1.25	1.40	1.65
A3	0.50	0.60	0.70
b	0.38	—	0.51
b1	0.37	0.42	0.47
c	0.18	—	0.25
c1	0.17	0.20	0.23
D	4.80	4.90	5.00
E	5.80	6.00	6.20
E1	3.80	3.90	4.00
e	1.17	1.27	1.37
L	0.45	0.60	0.80
L1	1.04REF		
L2	0.25BSC		
R	0.07	—	—
R1	0.07	—	—
h	0.30	0.40	0.50
θ	0°	—	8°
$\theta 1$	15°	17°	19°
$\theta 2$	11°	13°	15°
$\theta 3$	15°	17°	19°
$\theta 4$	11°	13°	15°

SOP-8 Package

NOTE:

1. Exceeding the maximum ratings of the device in performance may cause damage to the device, even the permanent failure, which may affect the dependability of the machine. Please do not exceed the absolute maximum ratings of the device when circuit designing.
2. When installing the heat sink, please pay attention to the torsional moment and the smoothness of the heat sink.
3. MOSFETs is the device which is sensitive to the static electricity, it is necessary to protect the device from being damaged by the static electricity when using it.
4. Shanghai Belling reserves the right to make changes in this specification sheet and is subject to change without prior notice.

CONTACT:

上海贝岭股份有限公司 (总部)

地址: 上海市宜山路 810 号

邮编: 200233

电话: 021-24261000

产品业务咨询及技术支持

电话: 021-24261326

传真 2: 021-64852222

邮箱 2: marketing@belling.com.cn

上海贝岭深圳分公司 (华南区)

地址: 深圳市福田区中心区民田路新华保险大厦 1510 室

邮编: 518031

电话: 0755-33336776 0755-33336770

传真: 0755-33336788

上海贝岭北京办事处 (华北区)

地址: 北京市西城区新华里 16 号院锦官苑小区 10 号楼 1 单元 1505 室

邮编: 100044

电话: 010-64179374

传真: 010-8835 9236